

Gx350i – Clean. Clear. Coding.



The **Gx350i** Thermal Ink Jet (TIJ) printer is Domino's coding specialist for multi-printhead operation, fast data transfer, and challenging controller environments across many industries. The small printheads can be mounted up to 25m from the IP64 rated controller. A 10" touchscreen with intuitive user interface enables easy and error-free operation and data input directly on board.

Easy to integrate

- ◆ Three connector options (front, back, top) on two printhead variants are available: the standard printhead (152mm high) and the compact printhead (93.4mm high).
- ◆ Fieldbus options like EtherCAT and Ethernet/IP: fast data transfer, integration with PLCs and precise synchronisation for motion control systems.
- ◆ Track & trace and item level serialisation via Dynamark protocol: 21 CFR Part 11 compliant, audit trail with comprehensive user administration, validation documentation available.

Easy to operate

- ◆ Easy printer operation and monitoring using the touch screen or via web browser.
- ◆ Automatic cartridge recognition and ink parameter setting.
- ◆ Continuous Operation: for uninterrupted production, the **AutoSwap** functionality enables cartridge change while printing. A Bulk Ink system is available for long-run operation without the need for any operator intervention.
- ◆ Operate four printheads from one controller for label height up to 50.8mm or multiple individual applications.

Clean. Clear. Coding.

- ◆ Graphic printing quality on paper, card, plastic, metal, and many other materials.
- ◆ Flexible label design: text, counters, clocks, graphics, logos, barcodes can all be included on the same label.
- ◆ Grade A code readability (ISO 15415) using Domino's inks on high density datamatrix codes*.

* module size 40x40, ≤ 169 characters



www.domino-printing.com



A complete solution

Our services are designed to provide operational insight so you can eliminate downtime and maximise production efficiency.

Operational support

An outstanding level of care, wherever you are. Our **SafeGuard** packages provide high-quality, on-site assistance and AR-enabled remote guidance from our engineers. **SafeGuard** helps to ensure we can be with you when you need us most.

Automatic code inspection

Ensure every code that leaves your factory is present and correct, and free up operator time. With the R-Series, Domino's range of vision control systems, you can automate your code inspection to validate code presence, placement, and readability.

Control software

Minimise errors using Domino's **QuickDesign** software. Control your product codes from a central location and streamline product changeovers. **QuickDesign** uses standard communication protocols and can be integrated into existing ERP systems.

Smart production

Gain operational insight by connecting your printer to **Domino Cloud**. Obtain production analytics dashboards and receive system error alerts. **Domino Cloud** provides you with the information you need to run your operations more efficiently.



Technical specification Gx350i

Controller dimensions	Height: 123.9mm Width: 322.4mm Depth: 250.7mm Weight: 6.4kg
Printhead dimensions	Standard printhead: height 152mm, width 50.9mm, depth 28.5mm, weight 0.22kg Compact printhead: height 98.5mm, width 93.4mm, depth 28.5mm, weight 0.17kg
Printhead cables	1.5, 3, 6, 12 or 25m
Printheads per controller	Up to 4 printheads for increased message height or individual printing on up to 4 different print positions
Print height	1 printhead: 12.7mm, 2 printheads: 25.4mm 3 printheads: 38.1mm, 4 printheads: 50.8mm
Print speed and resolution	300m/min at 60dpi to 30m/min at 600dpi
External connection options	2 encoders, I/Os for beacons, product detects or other; 2 USBs (type A), RS232C, 2x LAN
Power connector	3-way plug
Electrical supply	100-240 V AC, 50-60 Hz, 3.5 A
Controller operating temperature	0° - 45°C (32° - 113°F)
Operating relative humidity	20 - 80% RH (non condensing, 10°C increase per hour)
Controller finish	Stainless steel
Inks	A range of fast drying water and solvent based inks for porous and non-porous substrates, black, colours, and specialist inks
i-Techx features	Automatic ink cartridge detection, automatic ink parameter setting, automatic ink level recording
Communication	Ethernet / Dynamark protocol, EDC (serial, TCP, USB) optional: fieldbus protocols
User interface	QuickStep via 10" touch screen or customer HMI
Continuous operation options	Bulk Ink system for long-run operation, AutoSwap for uninterrupted production

Gx350i controller

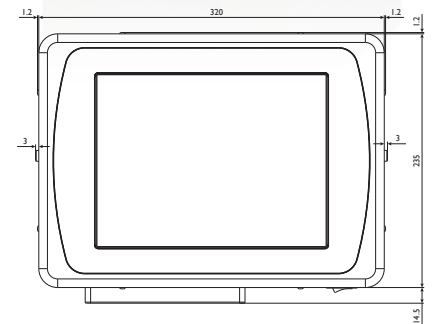

Printer bracket

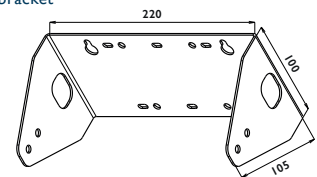

Gx-Series printhead

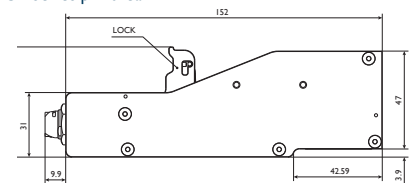

Gx-Series compact printhead

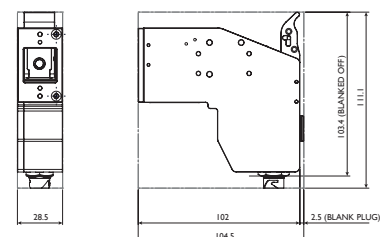

TALK TO AN EXPERT

Contact details: enquiries@domino-uk.com
Telephone: +44 1954 782 056
Website: www.domino-printing.com